



Cat[®] TH406

Telehandler

Specifications

Engine

Model		
Engine Model (Standard)	Cat [®] C4.4 Mechanical DITAAC	
Engine Model (Optional)	Cat [®] C4.4 Electronic DITAAC-ACERT™	
Gross Power (Standard)	74.5 kW	100 hp
Gross Power (Optional)	93.1 kW	125 hp
Maximum Torque (Standard)	410 Nm at 1400 rpm	
Maximum Torque (Optional)	496 Nm at 1400 rpm	
Bore	105 mm	4.13 in
Stroke	127 mm	4.99 in
Displacement	4.4 L	268.5 in ³

Weights

Operating Weight	7200 kg	15,870 lb
------------------	---------	-----------

Operating Specifications

Rated Load Capacity	3700 kg	8,150 lb
Maximum Lift Height	6.10 m	20 ft
Maximum Forward Reach	3.11 m	10 ft 2 in
Top Travel Speed	40 kph	25 mph
Capacity at Max Height	2500 kg	5,500 lb
Capacity at Max Reach	1500 kg	3,300 lb
Turning Radius over Tires	3.70 m	12 ft 2 in

Service Refill Capacities

Fuel Tank	150 L	39.63 gal
Hydraulic Tank	90 L	23.78 gal

Tires

Standard	15.5/80-24 16PR
Optional	400/80 R24 Power CL 460/70 R24 XMCL 15.50 x 25 SGL

Brakes

- Service brakes are inboard wet disc brakes on front axle
- Parking brakes are mechanical on front axle

Hydraulic System

Maximum System Pressure	250 bar	3,625 psi
Maximum Pump Flow	150 L/min	39.63 gal/min
Pump Type	Variable displacement load sensing axial piston pump	
Auxiliary Hydraulic Supply (Intermittent)	80 L/min	21.13 gal/min
Auxiliary Hydraulic Supply (Continuous)	60 L/min	15.85 gal/min

- Auxiliary Hydraulic Circuit used for all attachments equipped with cylinders or other hydraulic components. Consists of valves, controls, and hydraulic lines.

Transmission Speeds

Forward—1	7 kph	4.3 mph
Forward—2	12 kph	7.45 mph
Forward—3	21 kph	13 mph
Forward—4	32 kph	19.8 mph
Forward—5	40 kph	25 mph
Reverse—1	7 kph	4.3 mph
Reverse—2	12 kph	7.45 mph
Reverse—3	21 kph	13 mph

Boom Performance

Boom Up	5 Seconds	
Boom Down	4 Seconds	
Tele In	4.5 Seconds	
Tele Out	5 Seconds	
Tilt Forward (dump)	3 Seconds	
Tilt Backward	3 Seconds	
Combined—Up and Out	8 Seconds	
Combined—Down and In	6 Seconds	
Drawbar Pull 82.4 kW	8400 kg	18,520 lb
Drawbar Pull 86.8 kW	8849 kg	19,510 lb

Instruments

- Engine speed, boom angle, machine speed, operation hours, % of continuous flow selected, gear selected and direction

TH406 Telehandler

Dimensions

All dimensions are approximate.

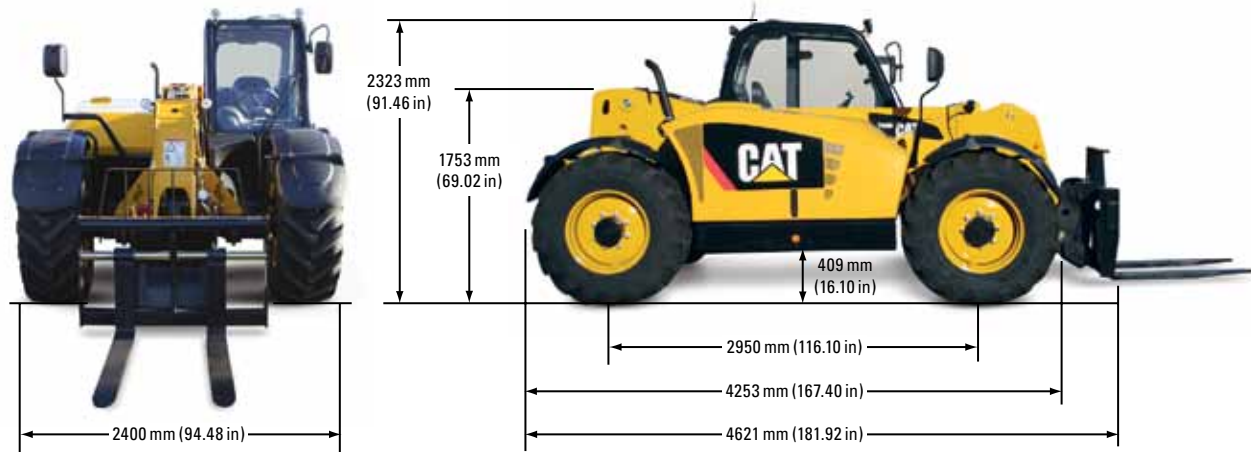

Load Chart and Dimensions

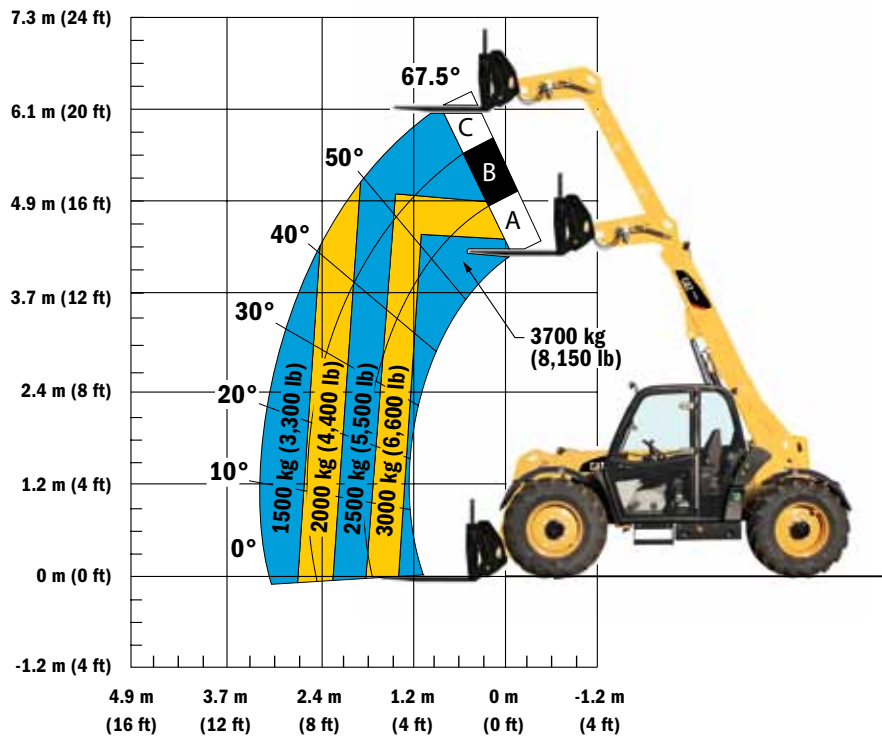

IMPORTANT

Rated lift capacities shown are with machine equipped with carriage and pallet forks. The machine must be level on a firm surface with undamaged, properly inflated tires. Machine specifications and stability are based on rated lift capacities at specific boom angles and boom lengths. (If specifications are critical, the proposed application should be discussed with your dealer.)

DO NOT exceed rated lift capacity loads, as unstable and dangerous machine conditions will result.

DO NOT tip the machine forward to determine the allowable load.

Use only JLG approved attachments with proper material handler model/attachment load capacity charts displayed in the operator's cab. OSHA requires all rough terrain forklift operators be trained according to OSHA 29 CFR 1910.178 (1).

Due to continuous product improvements, machine specifications and/or equipment changes may be made without prior notification. This machine meets or exceeds ANSI/ITSDF B56.6-2005 as originally manufactured for intended applications.